

## Brief Description of Blend-in Painting

### Brief Description of Blend-in Painting

Clean and sand damaged area. Apply putty, if necessary. Clean, degrease, apply filler to damaged area. Sand filler.

Sand the entire part beyond the damaged area. Give a matt finish to the adjoining part using sanding paste and Scotch Brite Type S ultra fine.

Mix basefix with 200% universal thinner. Apply one covering coat of basefix mixture to the entire surface of the adjoining part.

1st Layer: apply mixed base paint on the damaged part and fade out on adjoining part.

Note drying time. Do not blow-dry surfaces. Rub off surface using tack cloth.

2nd and 3rd layer: apply mixed base paint. Apply paint fading out past the perimeter zones of the first paint application. Allow to dry.

Rub down surface with tack cloth. Feather surface. Note spray pressure. Rub down surface with tack cloth.

Apply 1 feathering coat of mixed clear coat over both parts. Observe setting time.

Apply one more coat of clear coat. Then allow to set and dry.

Example: Fault in outer rear quarter panel. Blend-in paint adjoining part (rear door).

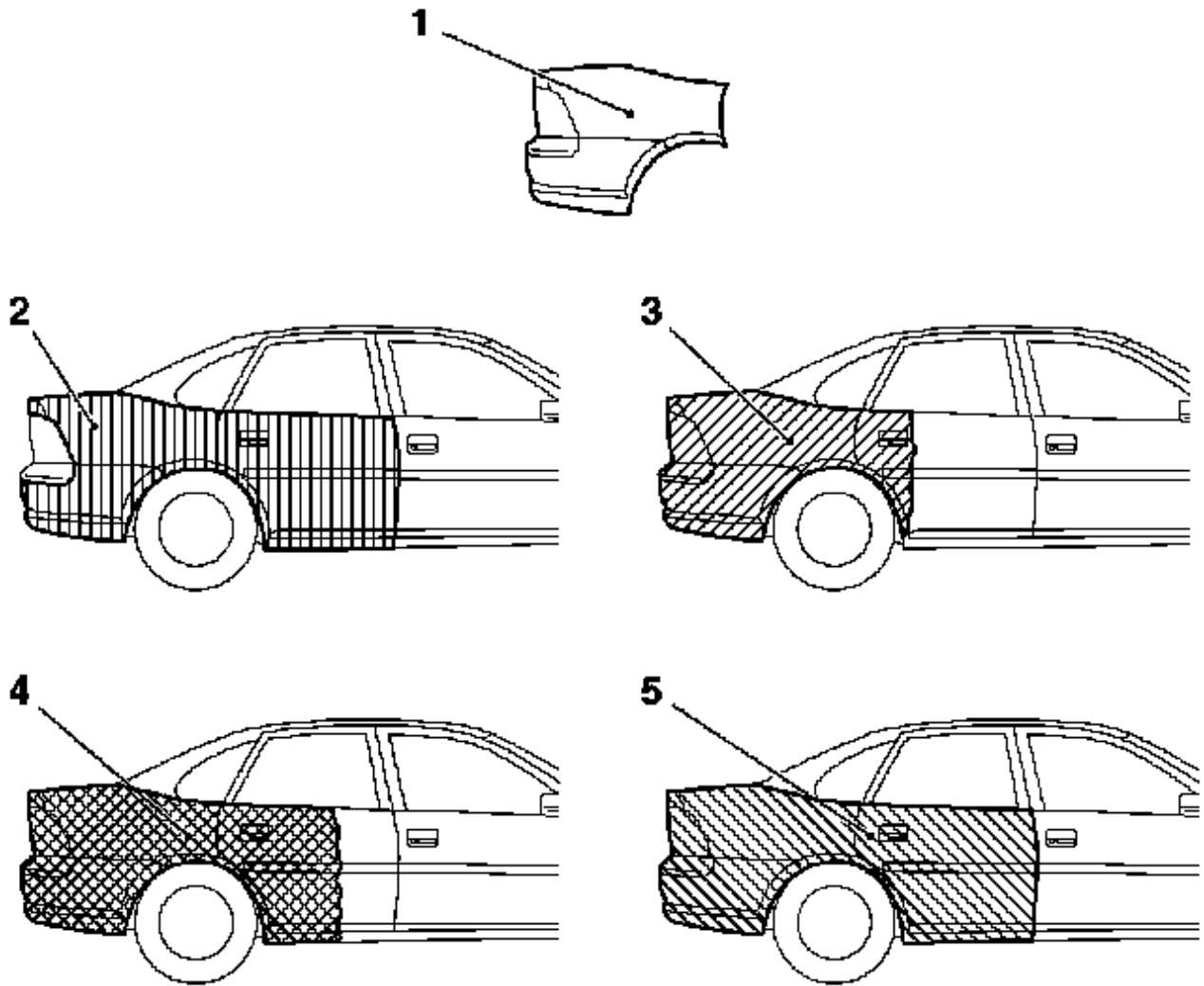

L0008453

**Paint system**

- 1 New part (or damaged part)
- 2 Apply basefix to repaired and adjoining part/surface
- 3 Apply base paint (to finish-sanded filler and adjoining part)
- 4 Fog zone 1/3
- 5 Apply Clear-coat (complete)